

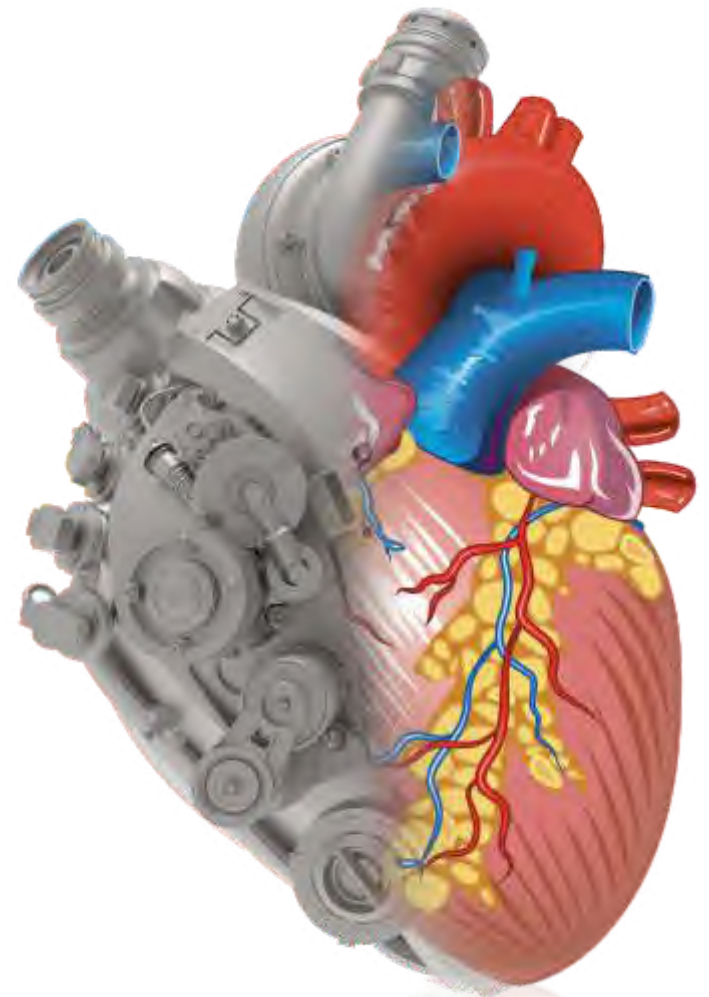

WE COMPETE
WITH ONLY
ONE PUMP



Over 5 Decades of
Providing Fluid Engineering
Excellence

A large, semi-transparent graphic in the background showing a Roto pump assembly overlaid on a human heart, symbolizing the company's focus on fluid engineering solutions for life and industry.

Our Vision

To be a leading fluid engineering
solution provider globally



The pumping of the human heart is the unmistakable sign of life and vitality. Over the last half-century, Roto's pumping solutions have become an integral part of the vital force behind industrial processes. With our pumps at the heart of industries world over, we feel that we are always with you. Our heart beats for you.



Growth Story Continues

Founded



1968

Introduced Twin Screw
Pumps in Technical
Collaboration with Stothert
& Pitt, UK



1980

Successful IPO –
Listed in Bombay Stock
Exchange



1994

Launched 3rd
Generation Extra Value
Cardan Joint Pump



1998

Commenced 2nd
Overseas Establishment
in the U.K.



2004



Launched our 2nd
Generation Progressive
Cavity Pumps

1976



Established 100%
Export Oriented Unit in
Noida, India

1988



Established Captive
Research & Development
Centre at Noida, India

1997



Started 1st Overseas
Establishment
in Australia

2000



Growth Story Continues



Penetrated in International Oil & Gas Sector



2008

2011



Entered in Commercial Marine & Defense Sector

Established new Manufacturing Plant at Greater Noida, India



2014

2015



Established 1st Overseas Subsidiary Company in USA

Established 2nd Overseas Subsidiary Company in South Africa



2016

2017



Successfully Launched Range of Gear Pumps & Air-Operated Diaphragm Pumps

Govt. Recognized R&D Centre, Noida, India



2018

2019



Established 3rd Overseas Subsidiary Company in Germany

Established 4th Overseas Subsidiary Company in Malaysia



2020

R&D Centre

- Equipped with advanced design softwares for 3D designing, Structural analysis & CFD.
- In-house prototype manufacturing & testing facility.
- In-house physical and chemical lab.

Elastomer Unit

- Advance manufacturing infrastructure with an in-house polymer test lab.
- In-house compound formulations and preparation.
- In-house mould design and manufacturing.

Manufacturing Unit

- Equipped with state-of-the-art machine tools including 5 Axis CNC Machining centre.
- Sophisticated measuring instruments including coordinate measuring machine.
- SCADA based real time pump testing facility.

Fabrication Unit

- Automatic laser cutting machines.
- CNC bending machines.
- Real time monitoring and log management of welding jobs.

ISO 9001, 14001 & 18001 Certified.



Engineering Excellence

Scada based real time pump testing facility





Global Presence

WE COMPETE
WITH ONLY
ONE PUMP
»»»



United States of America



Global HQ., India



Malaysia



United Kingdom



Germany



South Africa



Australia



Distinctive Products

Progressive Cavity Pumps

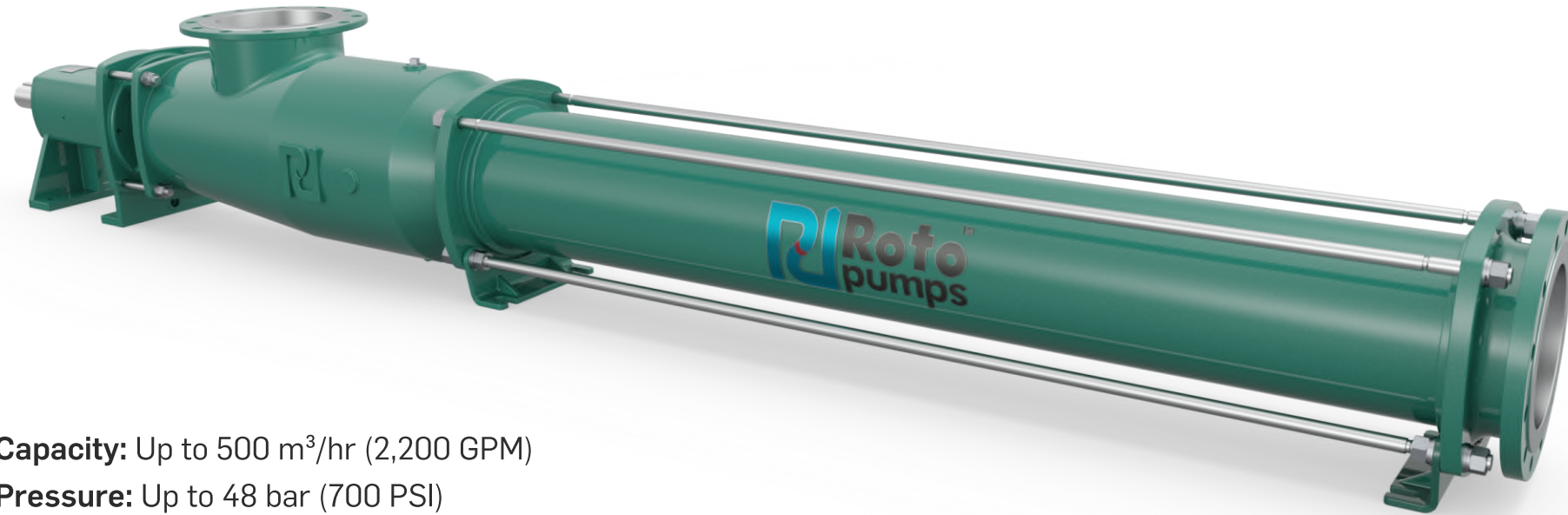

Capacity: Up to 500 m³/hr (2,200 GPM)
Pressure: Up to 48 bar (700 PSI)
Viscosity: Up to 3,000,000 cSt

Roto Progressive Cavity Pumps are designed to handle free flowing viscous abrasive fluids for wide spectrum of applications. These pumps have single rotating element which helps in delivering uniform, metered and non-pulsating flow.

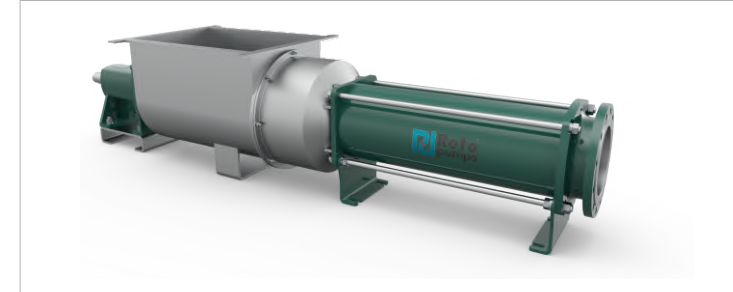

Wide Throat Pump

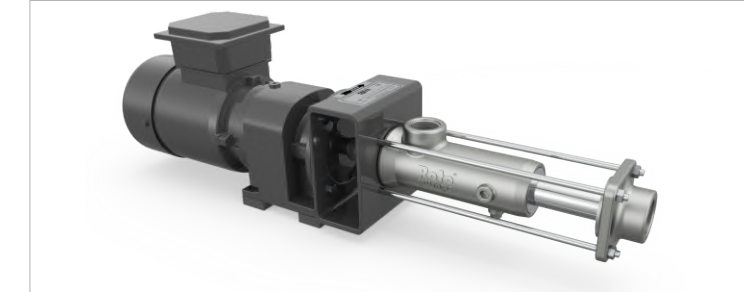

Dosing Pump



Food Pump



Roto KWIK Pump



Vertical Pump



Distinctive Products

Twin Screw Pumps >>>

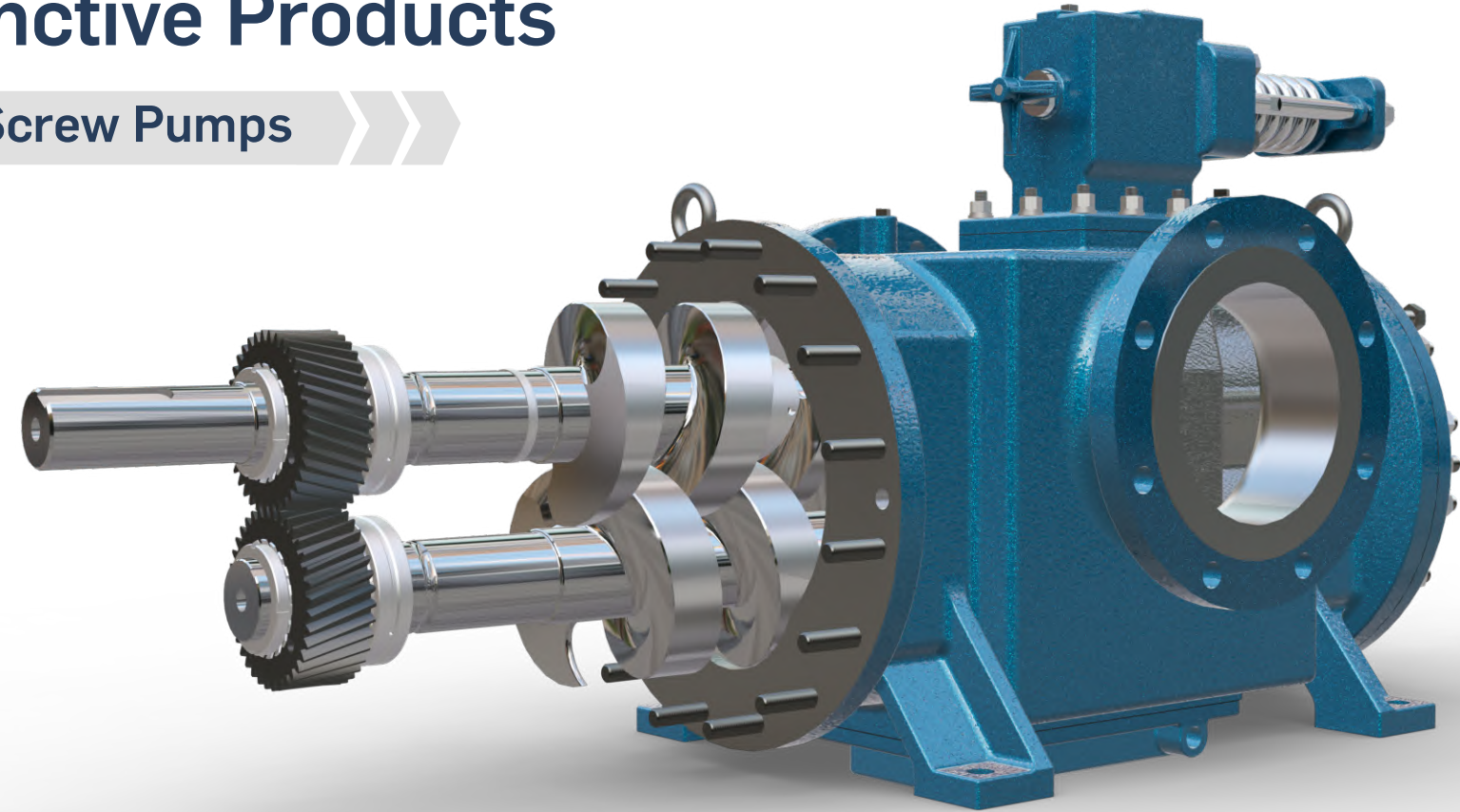

Capacity: Up to 940 m³/hr (4,140 GPM)
Pressure: Up to 30 bar (435 PSI)
Viscosity: Up to 100,000 cSt

Roto Twin Screw Pumps are designed to handle wide variety of clear lubricating, non-lubricating as well as aggressive liquids. These self-priming pumps are capable of handling entrapped air, vapour and gas due to positive displacement action. Moreover, these pumps have in-built relief valve.



Long Shaft Steam Jacketed Pump



Short Shaft Pump



Long Shaft Pump



Vertical Twin Screw Pump



Distinctive Products

Gear Pumps

Capacity: Up to 120 m³/hr (530 GPM)
Pressure: Up to 11 bar (160 PSI)
Viscosity: Up to 100,000 cSt

Roto's innovative external gear, double herringbone design pumps are compact, efficient and ensure longer service life. These pumps are specially designed to handle thin and thick liquids with minimal or no lubrication. These pumps can also be customized for high-pressure and high-temperature applications.



Process Transfer Duty Pump



Loading/ Unloading Duty Pump

Air Operated Diaphragm Pumps

Capacity: Up to 60 m³/hr (265 GPM)
Pressure: Up to 10 bar (145 PSI)
Viscosity: Up to 10,000 cSt

Roto diaphragm pumps are used for handling light to medium viscosity fluids, including: aggressive chemicals or liquids with heavy solids content. These pumps are built to resist corrosion and deliver a long, trouble-free product life.

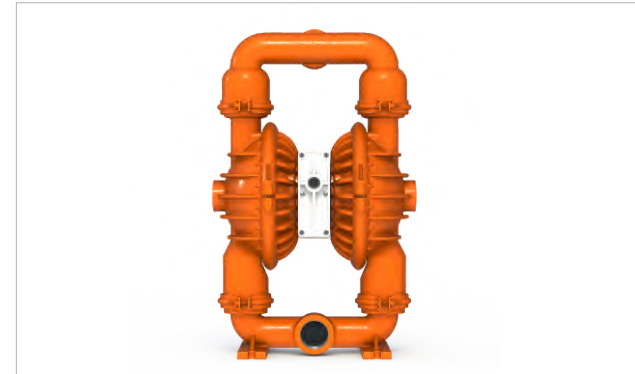

Aluminium Series Pump

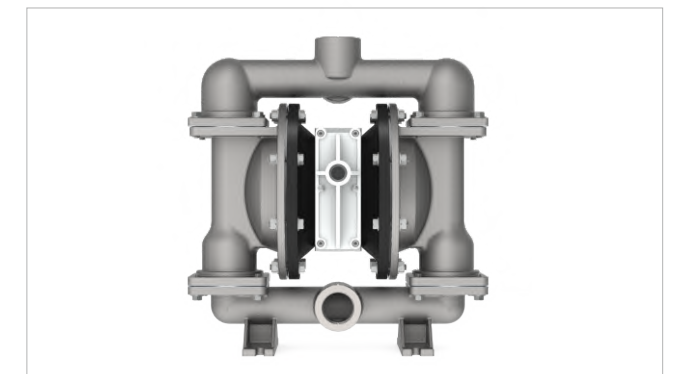

Stainless Series Pump



Diverse Applications Across Industries



Energy »»»

- Oil & Gas
- Nuclear Power
- Thermal Power
- Hydro Power
- Solar Power
- Biogas
- Coal Bed Methane



Environment & Agriculture »»»

- Municipal Wastewater
- Industrial Wastewater
- Water Treatment
- De-salination Plant
- Agriculture & Cattle Feed
- Construction & Tunneling



Defence, Marine & Shipbuilding »»»

- Submarine
- Navy
- Coast Guards
- Oil Tankers
- Commercial Liners
- Container Ships
- Ordnance & Defence Factories
- Floating, Production, Storage & Offloading



Chemical & Process »»»

- Paint & Varnish
- Paper & Pulp
- Viscose & Cellulose
- Adhesives & Sealants
- Polymers & Resins
- Inks & Dyes
- Petrochemicals
- Leather & Tanneries
- Textile
- Soaps & Detergents
- Carpet
- Wood Processing
- Fertilizer & Pesticides
- Rubber



Food & Pharmaceuticals »»»

- Dairy
- Bakery
- Sugar & Distillery
- Fruit Juice & Pulp
- Wine & Brewery
- Fish & Meat Processing
- Fisheries
- Fish Meal
- Edible Oil
- Pet Food
- Aroma & Flavours
- Starch & Glucose
- Pharma
- Herbal Products
- Cosmetics & Toiletries
- Catechu



Mining, Mineral Processing & Steel »»»

- Mining
- Ceramic
- Marble
- Metal Mining
- Explosives
- Mineral Processing
- Smelting
- Refractories
- Steel
- Clay
- Calcium Carbonate
- Coal Washeries

Winning Becomes a Habit

Recognitions

- Best Global Business Award
- Best SME in Global Outreach
- SME Business Excellence Award
- Engineering Goods Sector Award
- Export Excellence Award
- Star Performer Award



Delivering Excellent Service

24x7 Service Support

- Annual Maintenance Contract
- Pump Refurbishment
- Technical Support & On-site Training
- Roto Emergency Service Support
- Readily Available Spare Parts
- Installation Audit



We Care for Environment

Zero Liquid Discharge Plant

50% of our Energy needs met by the Solar Power Plant

Rainwater Harvesting



Being Socially Responsible

Govt. Junior School, Agahpur, Noida, UP, India

Continuous Upgradation of School Infrastructure to Ensure Quality Education for Underprivileged Children.

The Kalpatru Shiksha Kendra, Zewar, UP, India

Continuously Supporting the Educational and Athletic Development of 300+ Children including Uniforms, Shoes, Books and Stationery.

Roto Memorial Scholarship Award

Recognizing the Efforts of Meritorious Children of Roto Employees by providing Scholarships for Higher Education.





Roto Pumps North America Inc.

5889 S Garnett RD, Tulsa, Oklahoma 74146

Tel: +1 918 280 9144, Fax: +1 918 806 6853

Email: sales@rotopumpsna.com

www.rotopumpsna.com